



Zero Demand Growth Initiative

Presented To:

UNH Energy Conference

By:

*Kevin Sprague, P.E.
Director of Engineering*

June 20, 2008





Agenda

- Overview of Unitil
- Load Duration Curve
- Load Factor
- System Planning Implications
- Zero Demand Growth Initiative
- Pilot Project – Conceptual Ideas
- Questions



Overview

Who is Unitil?

- Public Utility Holding Company
- Operating Areas
 - Unitil Energy Systems (NH)
 - Capital - 29,600 cust.
 - Seacoast – 44,300 cust.
 - Fitchburg Gas & Electric Light Company – MA
 - Electric - 28,500 cust.
 - Gas - 15,000 cust

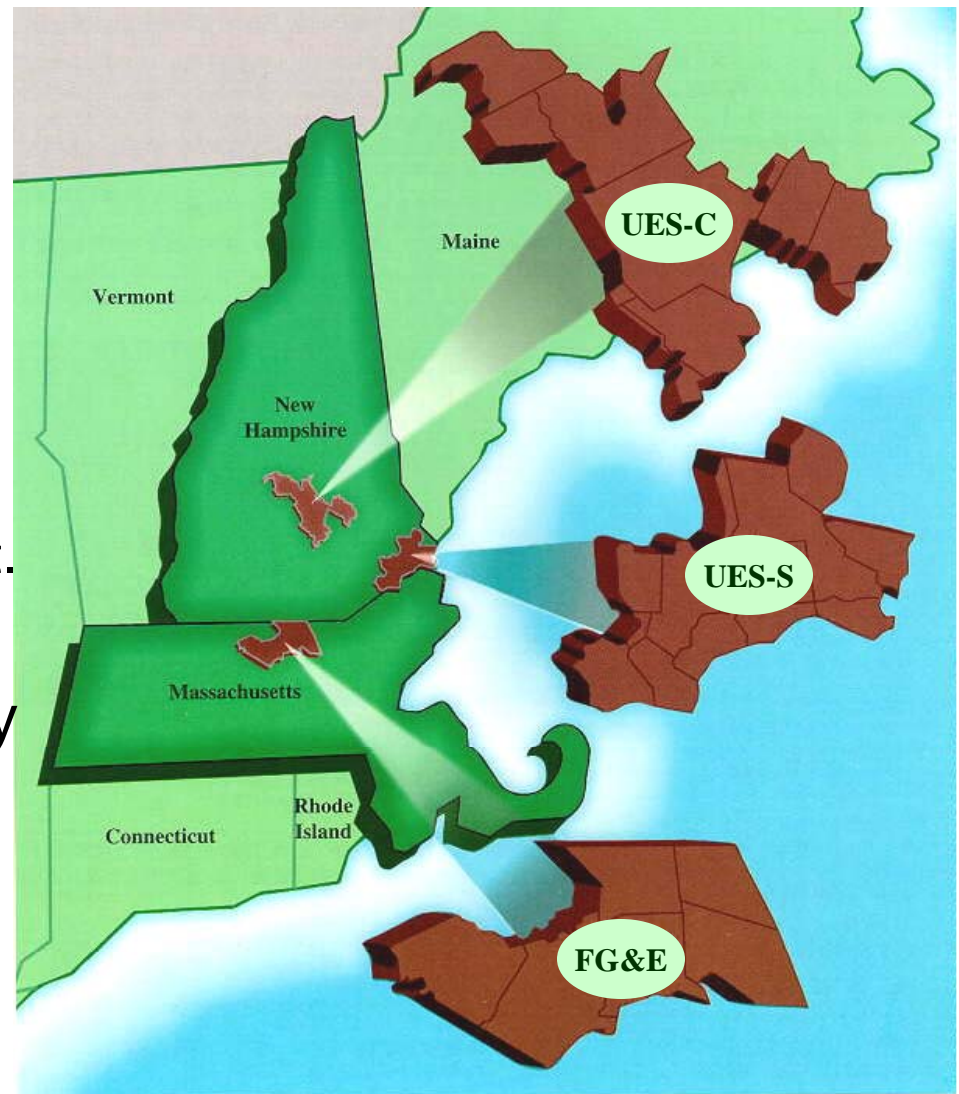



Load Duration Curves

Load Duration Curves

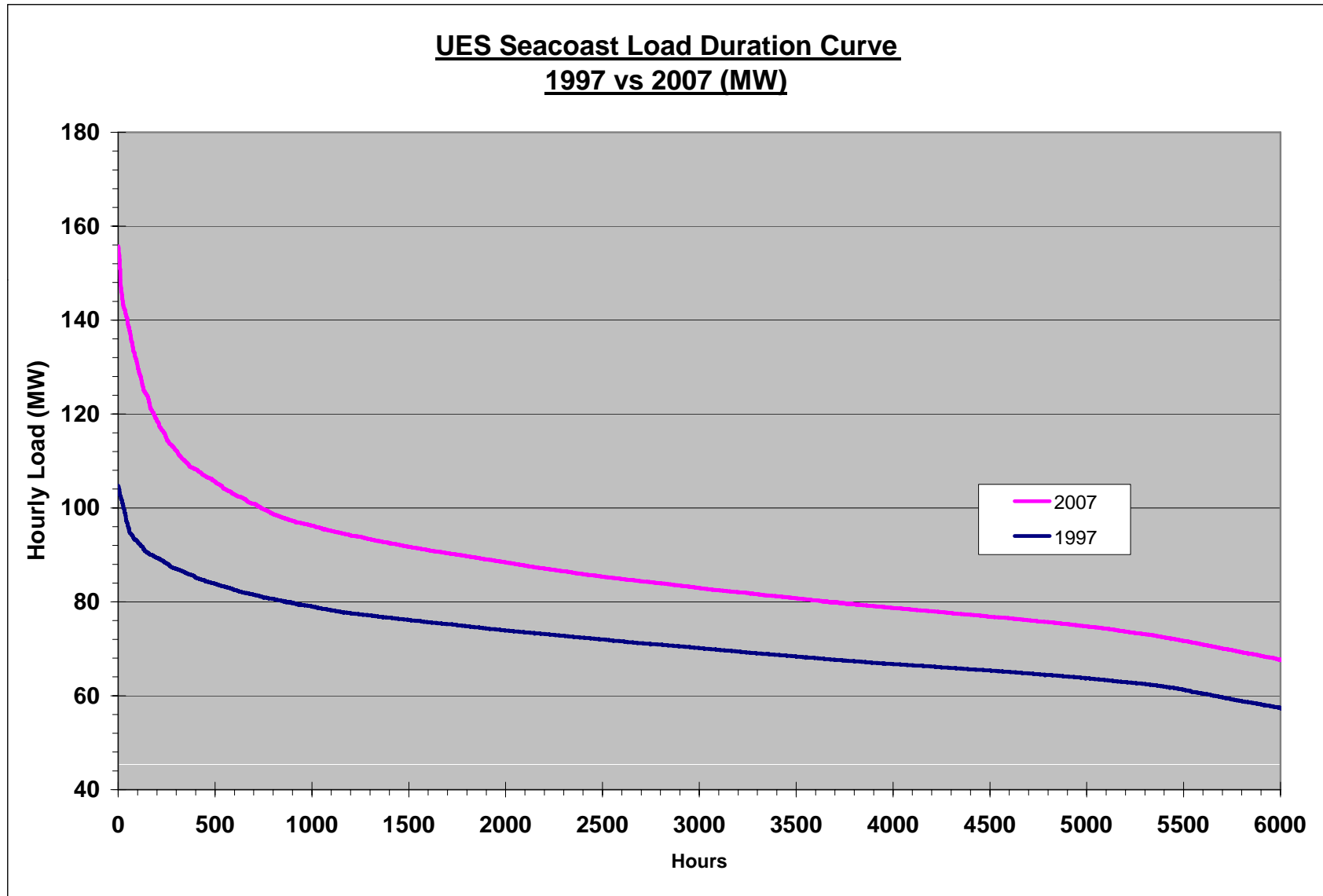

Load Duration Curves

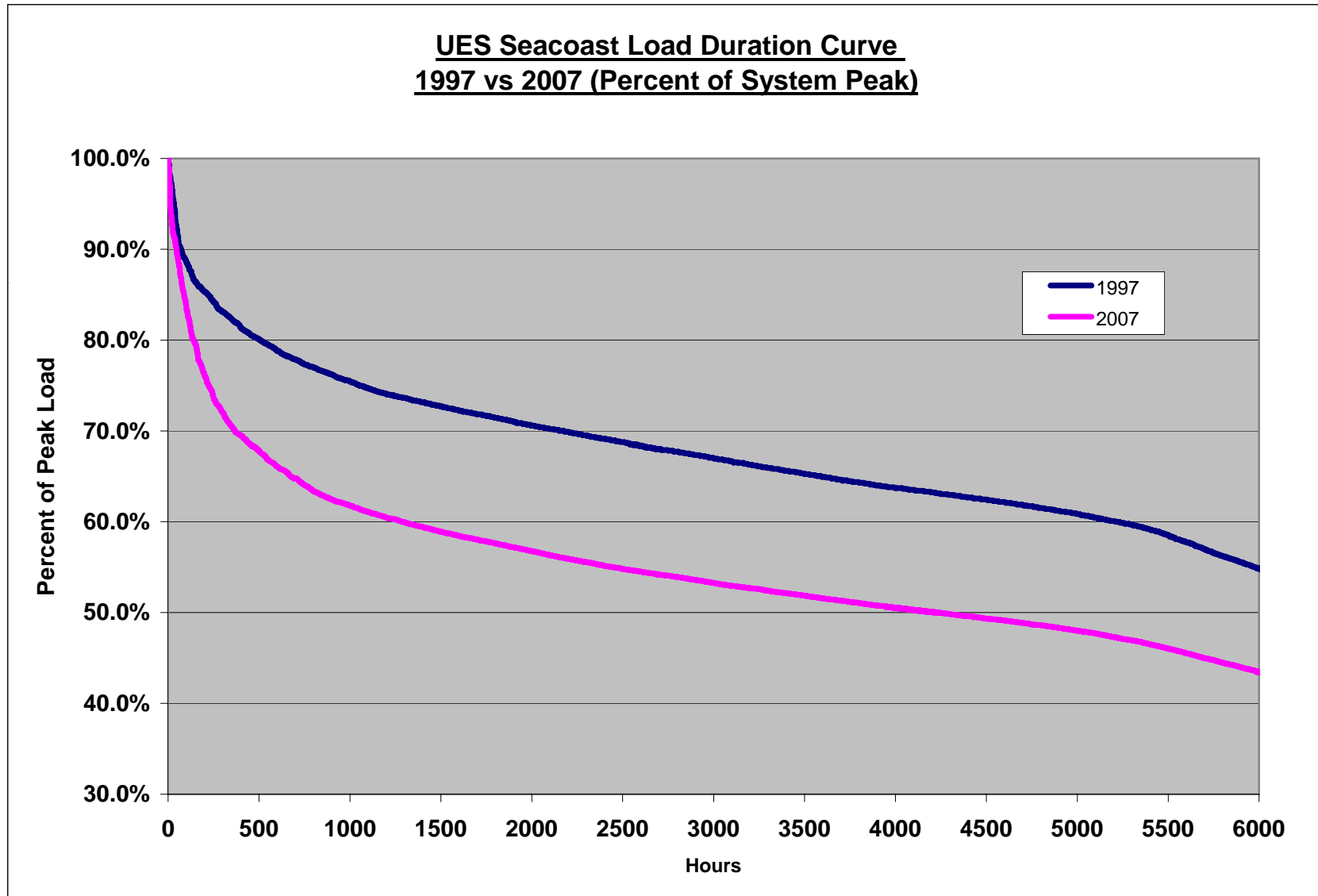

Load Duration Curves

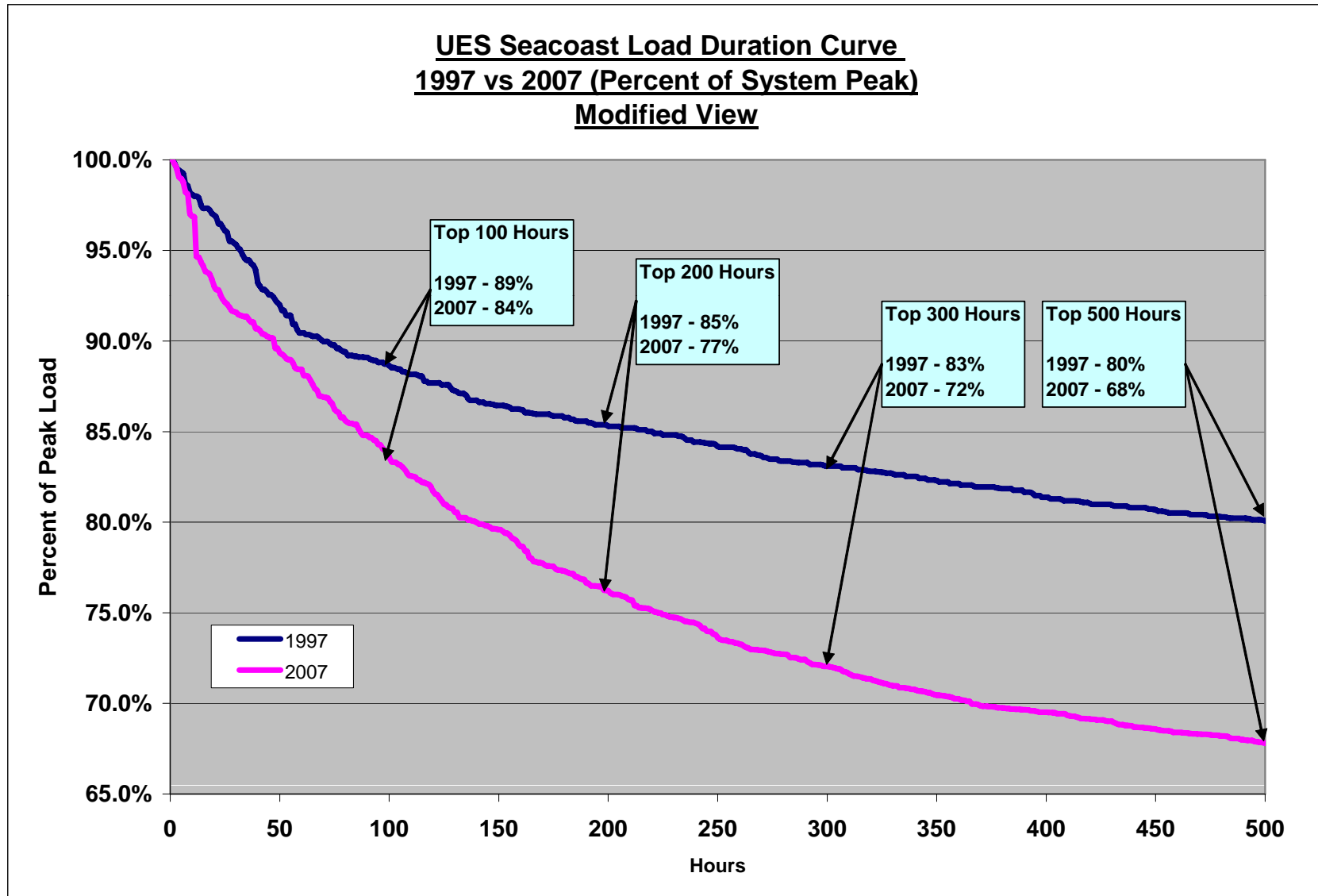



Load Factor

Load Factor

UES Seacoast
Representative Load Factor Graph

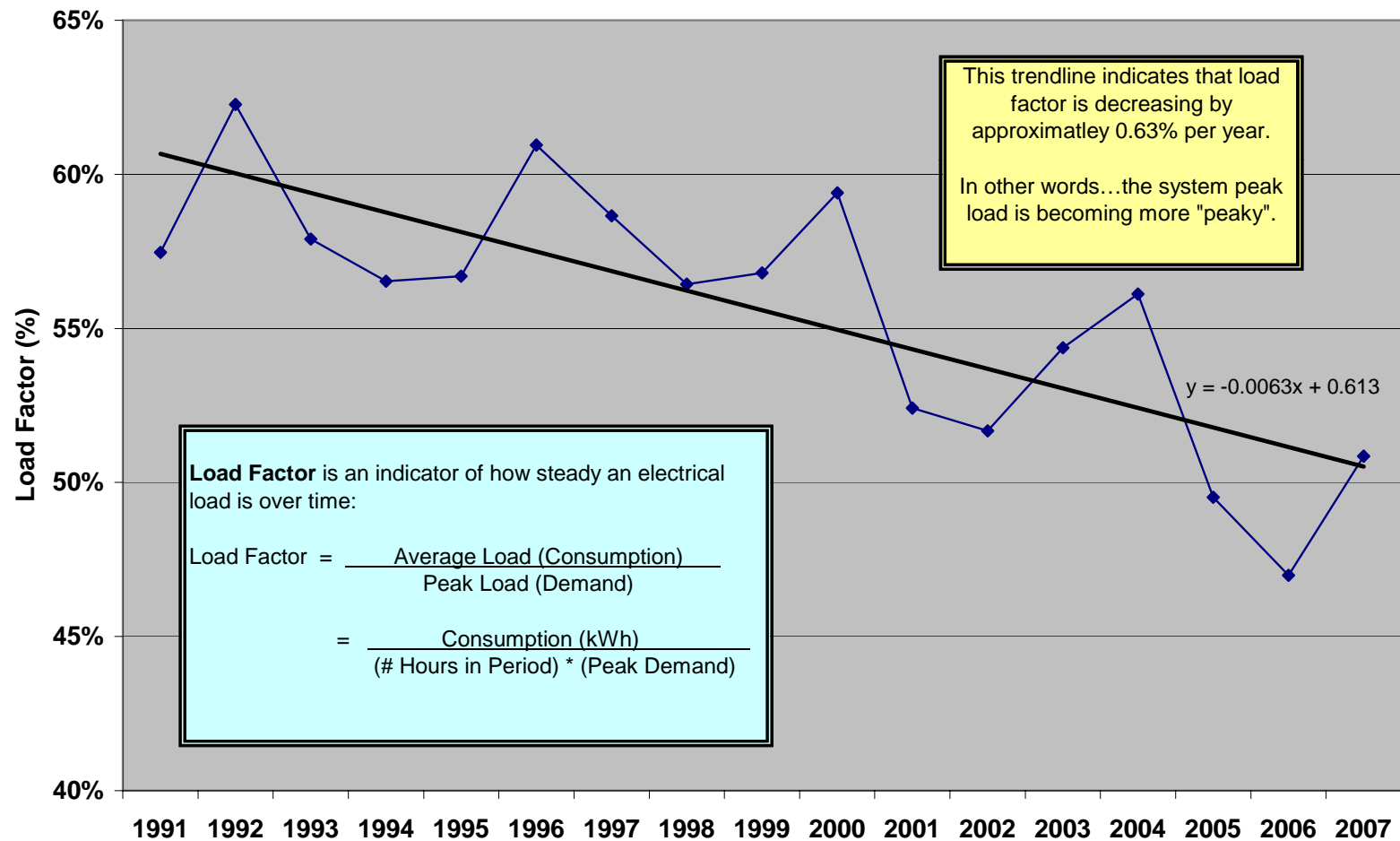



System Planning **Implications**

System Planning Implications

- Summer peaking load (air conditioning in NH)
- Electric systems must be built to meet the peak load
- System load > 90% of peak load on 47 hours of the year (0.5% of the year)
- Expensive investment sitting idle most of the year
- System peak load forecasted to increase resulting in a continued decrease in load factor
- What can be done??????



Zero Demand Growth **Initiative**

Zero Demand Growth

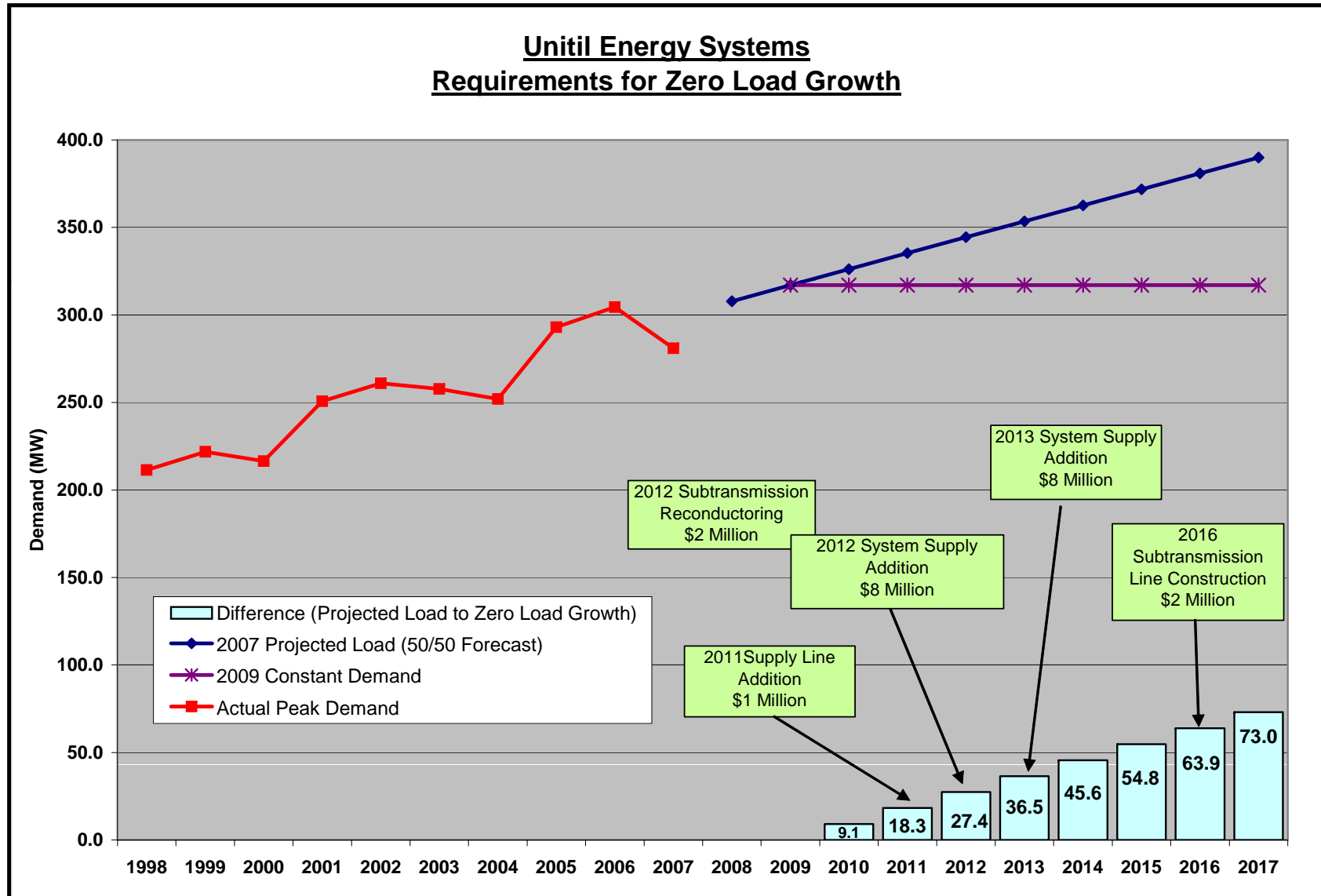

Zero Demand Growth

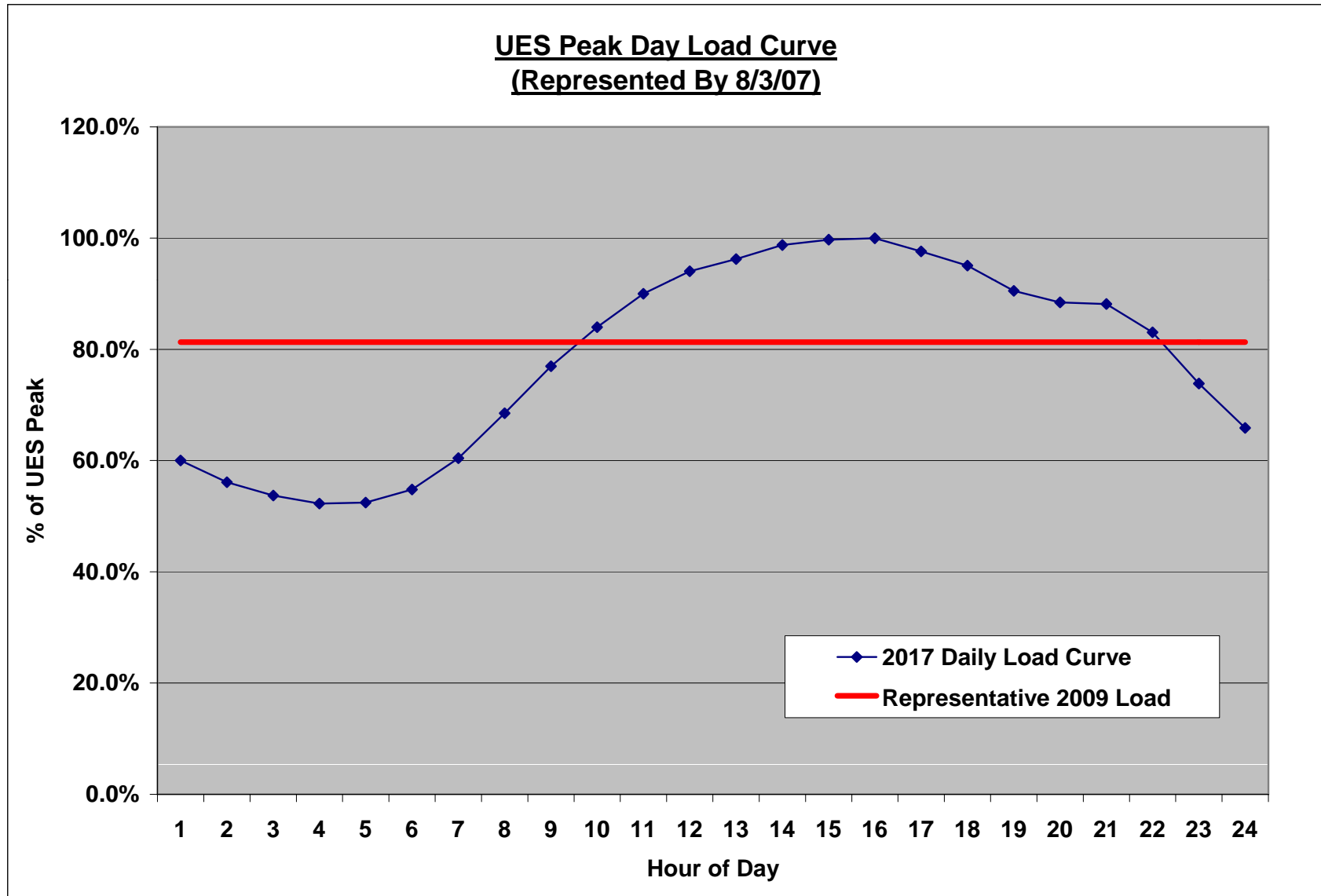

Zero Demand Growth

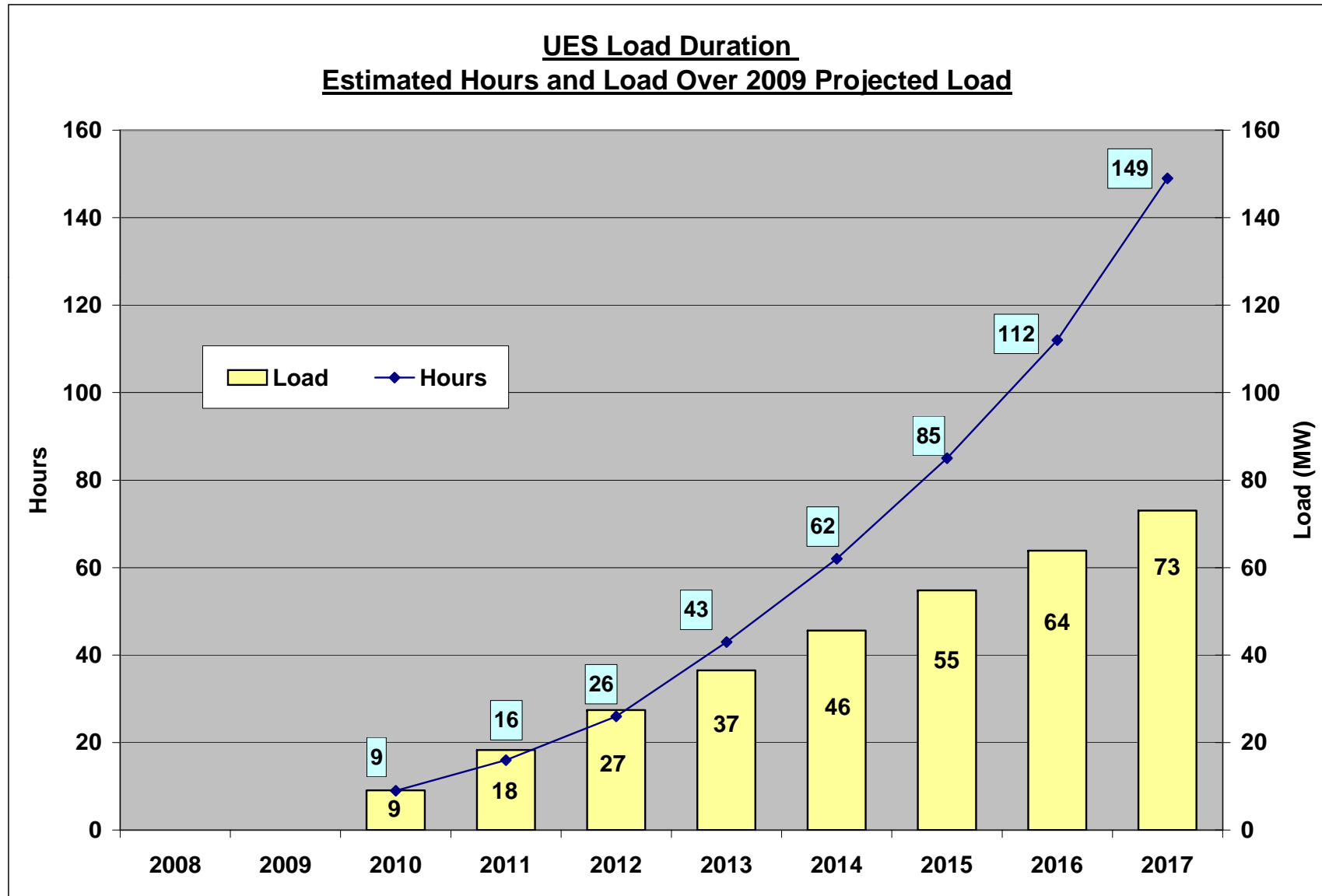



Distributed Energy **Resources**

Pilot Project Ideas

Ice Storage Pilot

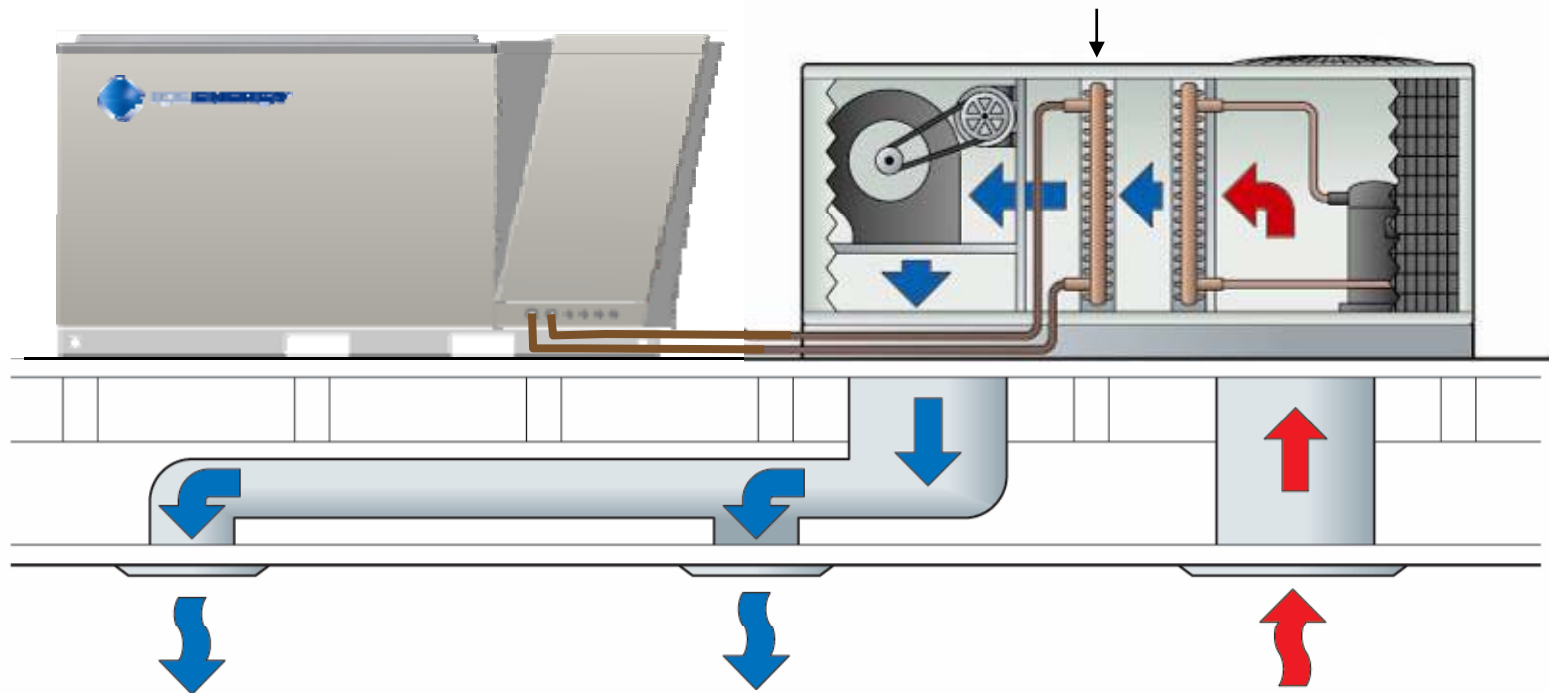

Ice Make Condensing unit refrigerant = R410A
Nominal Specifications:
Energy Storage Capacity = 32 Ton-hours
Evaporator Coil Size = 5 Tons
Peak Day Demand Reduction = 5 KW (95% peak demand reduction)
Full Ice Melt Load Shift = 32 KW-hours
Round-Trip Energy Efficiency = Neutral +/- 5%

Wind Pilot

Technical Specifications:

Model: Skystream 3.7

Rated Capacity: 1.9 kW continuous output, 2.6 kW peak

Weight: 170 lb (77 kg)

Rotor Diameter: 12 ft (3.72 m)

Rated Speed: 50 - 325 rpm

Maximum Tip Speed: 216.5 ft/s (66 m/s)

Voltage Output: 120-240 VAC 50-60 Hz

Cut-in Wind Speed: 8 mph (3.5 m/s)

Rated Wind Speed: 21 mph (9.4 m/s)

User Control: Wireless 2 way interface remote system

Survival Wind: Speed 140 mph (63 m/s)



TOU Rates with Load Control

 ZigBee® Alliance
ZigBee Smart Energy

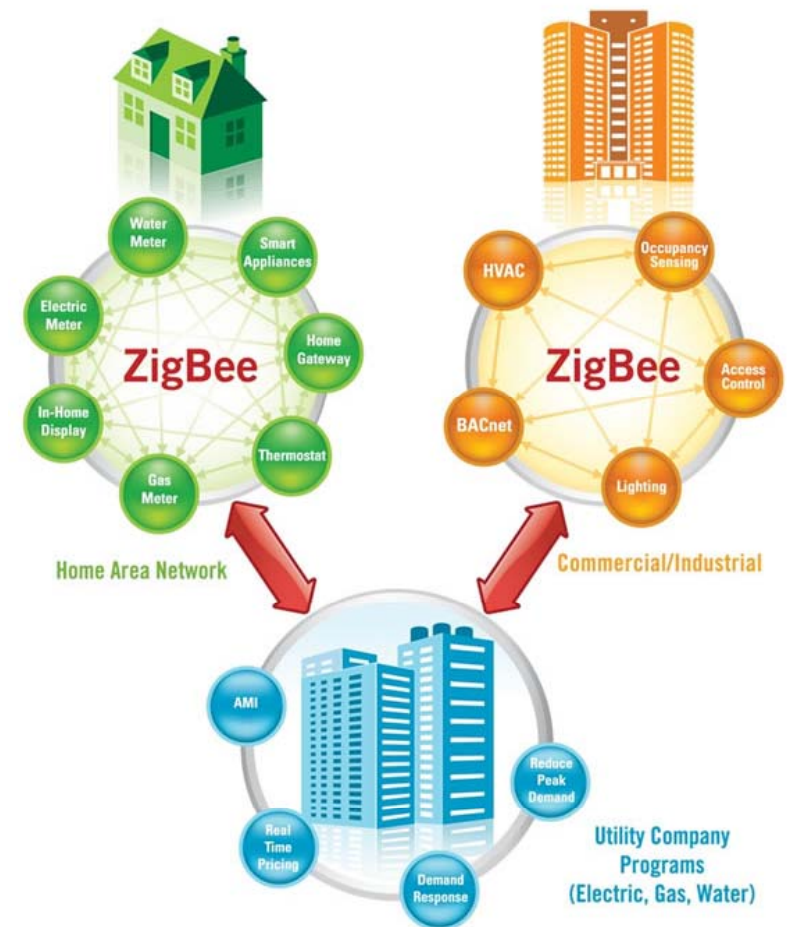
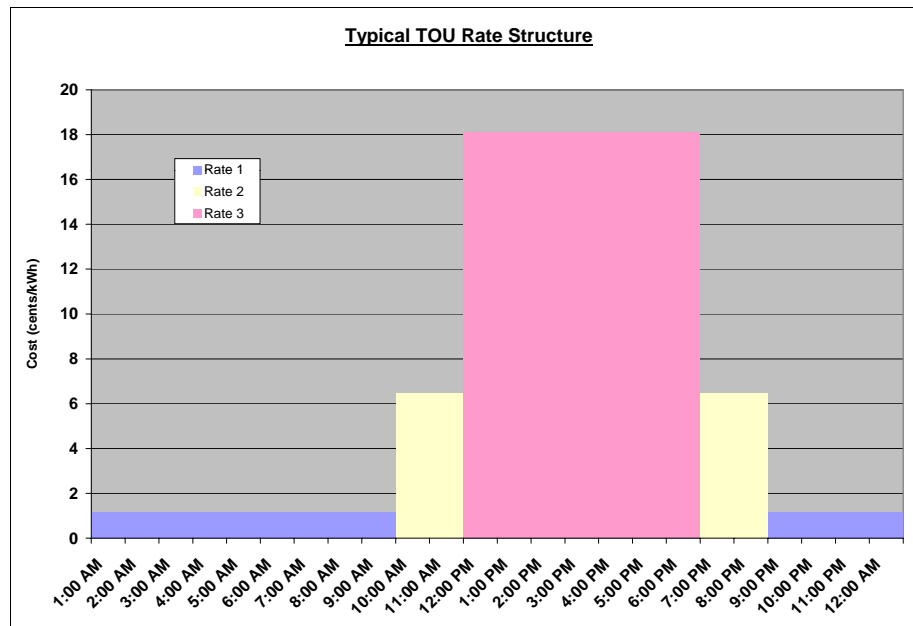

Diagram property of ZigBee® Alliance

Other Pilot Projects

- PV Systems
- Direct Load Control
- Landfill Generation
- Hotel Occupancy Thermostats
- Central AC Retrofit Program
- Window AC Trade-in Program
- Gas Cooling
- And several more.....



Questions

Contact Information

Kevin Sprague P.E.

Unitil

Director of Engineering

sprague@unitil.com